

Configuration Data

Model **C92** **1** - **363SI**

Electronic Metering Pumps

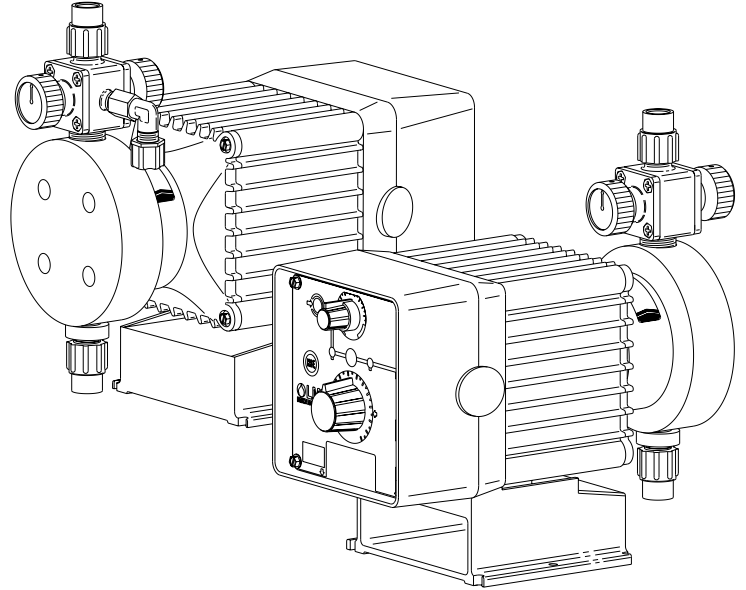

Control & Output Code	
Manual Control	
Speed (stroking frequency) and stroke length manually adjustable.	
C10	--- 1.3 GPH (4.9 l/h) ... 300 psi (20.7 Bar)
C11	--- 2.5 GPH (9.5 l/h) ... 150 psi (10.3 Bar)
C12	--- 4.0 GPH (15.1 l/h) ... 100 psi (6.9 Bar)
C13	--- 8.0 GPH (30 l/h) 60 psi (4.1 Bar)
C14	--- 20 GPH (76 l/h) 25 psi (1.7 Bar)
Instrument Responsive/Manual Control	
Manual adjustment features of C1 Series plus switch conversion to external control for automatic systems.	
C70	--- 1.3 GPH (4.9 l/h) ... 300 psi (20.7 Bar)
C71	--- 2.5 GPH (9.5 l/h) ... 150 psi (10.3 Bar)
C72	--- 4.0 GPH (15.1 l/h) ... 100 psi (6.9 Bar)
C73	--- 8.0 GPH (30 l/h) 60 psi (4.1 Bar)
C74	--- 20 GPH (76 l/h) 25 psi (1.7 Bar)
C76	--- 4.0 GPH (15.1 l/h) 175 psi (12.1 Bar)
C77	--- 10 GPH (38 l/h) 80 psi (5.5 Bar)
C78	--- 25 GPH (95 l/h) 30 psi (2.07 Bar)
C90	--- 1.3 GPH (4.9 l/h) ... 300 psi (20.7 Bar)
C91	--- 2.5 GPH (9.5 l/h) ... 150 psi (10.3 Bar)
C92	--- 4.0 GPH (15.1 l/h) ... 100 psi (6.9 Bar)
C93	--- 8.0 GPH (30 l/h) 60 psi (4.1 Bar)
C94	--- 20 GPH (76 l/h) 25 psi (1.7 Bar)

Voltage Code	
1	----- 120 VAC US Plug
2	----- 240 VAC US Plug
3	----- 220-240 VAC DIN Plug
5	----- 240-250 VAC, UK Plug
6	----- 240-250 VAC, AUST/NZ Plug
7	----- 220-240 VAC, SWISS Plug

Liquid End
See next page for complete liquid end specifications and selection.

Dimensions

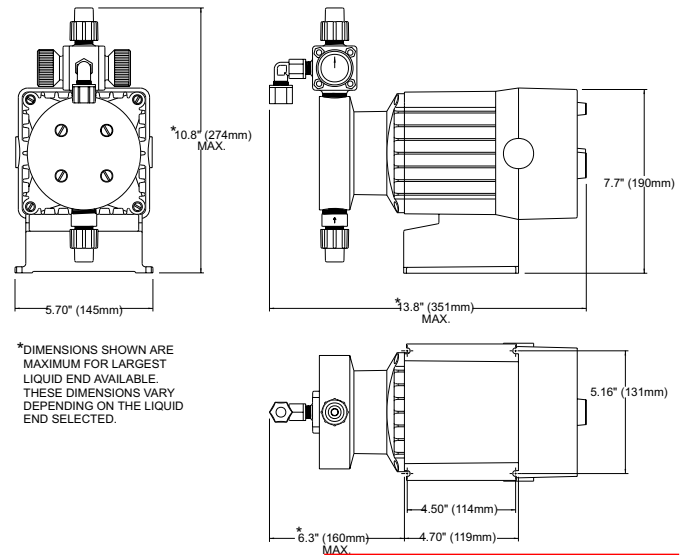

Specifications

Series	Strokes Per Minute (Adjustable)		Stroke Length (Adjustable) Recommended Minimum	Average Input Power @ Max Speed	Shipping Weight
	Min	Max			
C10, C70, C90 C11, C71, C91 C12, C72, C92 C13, C73, C93 C14, C74, C94	1	100	10%	44 watts	20 lbs (9.1 kg)
C76 C77 C78	1	100	10%	87 watts	28 lbs (12.7 kg)



5044 Industrial Road
Suite C
Farmingdale, NJ 07727
TEL: (800) 810-1053
FAX: (732)223-2587
www.pumpcatalog.com



Configuration Data & Materials of Construction

Drive Assembly	Liquid End No.	Size Code	Materials of Construction				Accessory	Tubing & Connections	
			Head & Fittings	Balls	Liquifram™	Check Valve		Discharge	Suction
C90 ■ -	498SP	0.9	PVC	Ceramic	Fluorofilm™	PTFE	4FV	Pipe 1/4" NPT M	
C70 ■ -	297	0.9	316 S.S.	316 S.S.	Fluorofilm™	316 S.S.		Pipe 1/4" NPT M	
C10 ■ -									

C92 ■ - C91 ■ - C72 ■ - C71 ■ - C12 ■ - C11 ■ -	468SI	1.8	PVC / PVC	Ceramic	Fluorofilm™	PVDF / Polyprel®	4FV	PE .375" O.D.	
	460SI	1.8	Acrylic / PVC	Ceramic	Fluorofilm™	PVDF / Polyprel®	4FV	PE .375" O.D.	
	460FI	1.8	Acrylic / PVC	PTFE	Fluorofilm™	PVDF / Polyprel®	4FV	PE .375" O.D.	
	368SI	1.8	PVC / PVC	Ceramic	Fluorofilm™	PVDF / Polyprel®	4FV	PE .375" O.D.	
	362SI	1.8	PVDF / PVDF	Ceramic	Fluorofilm™	PVDF / Polyprel®	4FV	PE .375" O.D.	
	363SI	1.8	PVDF / PVDF	Ceramic	Fluorofilm™	PVDF / PTFE	4FV	PE .375" O.D.	
	75HV	1.8	Polypropylene	316 S.S.	Fluorofilm™	PTFE		PE .5" O.D. Vinyl .938" O.D.	
	75S*	1.8	Polypropylene	Ceramic	Fluorofilm™	PTFE	4FV	PE .5" O.D.	
	76HV	1.8	Acrylic/PP	316 S.S.	Fluorofilm™	Hypalon®		PE .5" O.D. Vinyl .938" O.D.	
	79	1.8	UHMW PE	Ceramic	Hypalon®	Hypalon®		PE .5" O.D. Vinyl .5" O.D.	
277	1.8	316 S.S.	316 S.S.	Fluorofilm™	316 S.S.		Pipe 1/4" NPT M		

C93 ■ - C73 ■ - C13 ■ -	418SI#	3.0	PVC / PVC	Ceramic	Fluorofilm™	PVDF / Polyprel®	4FV	PE .5" O.D.	
	410SI#	3.0	Acrylic / PVC	Ceramic	Fluorofilm™	PVDF / Polyprel®	4FV	PE .5" O.D.	
	410FI#	3.0	Acrylic / PVC	PTFE	Fluorofilm™	PVDF / Polyprel®	3FV	PE .5" O.D.	
	318SI#	3.0	PVC / PVC	Ceramic	Fluorofilm™	PVDF / Polyprel®	4FV	PE .5" O.D.	
	313SI#	3.0	PVDF / PVDF	Ceramic	Fluorofilm™	PVDF / PTFE	4FV	PE .5" O.D.	
	312SI#	3.0	PVDF / PVDF	Ceramic	Fluorofilm™	PVDF / Polyprel®	4FV	PE .5" O.D.	
	20HV	3.0	Acrylic / PP	316 S.S.	Fluorofilm™	Hypalon®		PE .5" O.D. Vinyl .938" O.D.	
	22	3.0	PVDF	Ceramic	Fluorofilm™	PTFE		PE .5" O.D.	
	22P	3.0	PVDF	Ceramic	Fluorofilm™	PTFE		Pipe 1/2" NPT M	
	24	3.0	PVC	Ceramic	Fluorofilm™	PTFE		Pipe 1/2" NPT M	
	25HV	3.0	Polypropylene	316 S.S.	Fluorofilm™	PTFE		PE .5" O.D. Vinyl .938" O.D.	
	25P	3.0	Polypropylene	Ceramic	Fluorofilm™	PTFE		Pipe 1/2" NPT M	
	25T	3.0	Polypropylene	Ceramic	Fluorofilm™	PTFE		PE .5" O.D.	
	27	3.0	316 S.S.	316 S.S.	Fluorofilm™	PTFE		Pipe 1/2" NPT M	
	29	3.0	UHMW PE	Ceramic	Fluorofilm™	Hypalon®		PE .5" O.D.	

C94 ■ - C78 ■ - C74 ■ - C14 ■ -	30	6.0	Acrylic/PVC	Ceramic	Fluorofilm™	PTFE		PE .5" O.D. Vinyl .5" O.D.	
	32	6.0	PVDF	Ceramic	Fluorofilm™	PTFE		PE .5" O.D.	
	32P	6.0	PVDF	Ceramic	Fluorofilm™	PTFE		Pipe 1/2" NPT M	
	34	6.0	PVC	Ceramic	Fluorofilm™	PTFE		Pipe 1/2" NPT M	
	35P	6.0	Polypropylene	Ceramic	Fluorofilm™	PTFE		Pipe 1/2" NPT M	
	35T	6.0	Polypropylene	Ceramic	Fluorofilm™	PTFE		PE .5" O.D.	
	36	6.0	PVC	Ceramic	Fluorofilm™	PTFE		PE .5" O.D.	
37	6.0	316 S.S.	316 S.S.	Fluorofilm™	PTFE		Pipe 1/2" NPT M		

C76 ■ -	468SP	1.8	PVC/PVC	Ceramic	Fluorofilm™	PVDF / Polyprel®	4FV	PE .375" O.D.	
	74S	1.8	Polypropylene	Ceramic	Fluorofilm™	PTFE	4FV	Pipe 1/4" NPT M	
	277	1.8	316 S.S.	316 S.S.	Fluorofilm™	316 S.S.		Pipe 1/4" NPT M	

C77 ■ -	20HV	3.0	Acrylic/PP	316 S.S.	Fluorofilm™	Hypalon®		PE .5" O.D. Vinyl .938" O.D.	
	20S**	3.0	Acrylic/PVC	Ceramic	Fluorofilm™	Hypalon®	4FV	PE .5" O.D. Vinyl .5" O.D.	
	22	3.0	PVDF	Ceramic	Fluorofilm™	PTFE		Pipe 1/2" NPT M	
	22P	3.0	PVDF	Ceramic	Fluorofilm™	PTFE	4FV	Pipe 1/2" NPT M	
	24	3.0	PVC	Ceramic	Fluorofilm™	PTFE		Pipe 1/2" NPT M	
	25HV	3.0	Polypropylene	316 S.S.	Fluorofilm™	PTFE		PE .5" O.D. Vinyl .938" O.D.	
	25P	3.0	Polypropylene	Ceramic	Fluorofilm™	PTFE		Pipe 1/2" NPT M	
	25T	3.0	Polypropylene	Ceramic	Fluorofilm™	PTFE		PE .5" O.D.	
	26S**	3.0	PVC	Ceramic	Fluorofilm™	Viton®	4FV	PE .5" O.D.	
	27	3.0	316 S.S.	316 S.S.	Fluorofilm™	PTFE		Pipe 1/2" NPT M	
	29	3.0	UHMW PE	Ceramic	Fluorofilm™	Hypalon®		PE .5" O.D.	

■ See front page for voltage code specifications.

**These Liquid Ends are available without a 4FV, simply drop the 'S' at the end of the Liquid End number to order the model without a 4FV.

#These liquid ends use 3/8" diameter balls. Pump output may be reduced in some applications.

*To specify 1/4" NPT male, change 'I' to 'P'. To specify black, UV resistant tubing, change 'I' to 'U'. To specify Bleed 4FV, change 'S' to 'B'. To specify 3FV, change 'S' to 'T'.

Fluorofilm™ is a copolymer of PTFE and PFA. Polyprel® is an elastomeric PTFE copolymer.

4FV indicates that the pump is equipped with an LMI Four Function Valve. This diaphragm type anti-syphon/pressure relief valve is installed on the pump head. It provides anti-syphon protection and aids in priming, even under pressure.

Output Information

Series	Gallons per Hour		Liters per Hour		mL/cc per Minute		mL/cc per Stroke		Maximum Injection Pressure
	Min	Max	Min	Max	Min	Max	Min	Max	
C10, C70*, C90*	0.001	1.3	0.005	4.9	0.08	82	0.08	0.82	300 psi (20.7 Bar)
C11, C71*, C91*	0.003	2.5	0.010	9.5	0.16	158	0.16	1.58	150 psi (10.3 Bar)
C12, C72*, C92*	0.004	4.0	0.015	15.1	0.25	252	0.25	2.52	100 psi (6.9 Bar)
C13, C73*, C93*	0.008	8.0	0.030	30.0	0.51	505	0.51	5.05	60 psi (4.1 Bar)
C14, C74*, C94*	0.020	20.0	0.076	76.0	1.26	1262	1.26	12.62	25 psi (1.7 Bar)
C76*	0.004	4.0	0.015	15.1	0.25	252	0.25	2.52	175 psi (12.1 Bar)
C77*	0.010	10.0	0.038	38.0	0.63	631	0.63	6.31	80 psi (5.5 Bar)
C78*	0.025	25.0	0.095	95.0	1.58	1577	1.58	15.77	30 psi (2.07 Bar)

*Minimum output is based on 1 stroke per minute and 10% stroke setting, minimum output can be reduced further in external mode. Series C9 pumps may be programmed for strokes per hour for lower outputs.